

## DIN 7991-ISO 10642

Vis à tête fraisée plate à six pans creux

Hexagon socket countersunk head screw

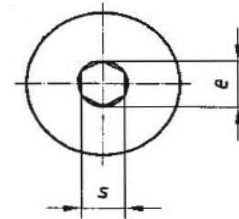
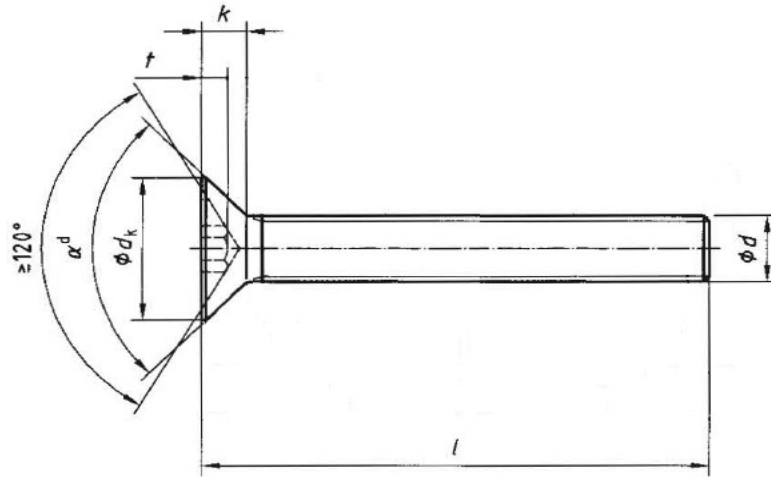

d	M3	M4	M5	M6	M8	M10	M12	M14	M16	M20
dk max.	6,72	8,96	11,2	13,44	17,92	22,4	26,88	30,8	33,6	40,32
e min.	2,303	2,873	3,443	4,583	5,723	6,863	9,149	11,429	11,429	13,716
k max.	1,86	2,48	3,1	3,72	4,96	6,2	7,44	8,4	8,8	10,16
s nom.	2	2,5	3	4	5	6	8	10	10	12
t min.	1,1	1,5	1,9	2,2	3	3,6	4,3	4,5	4,8	5,6

Disponible:

Acier Inoxydable

A2

A4

Acier au carbone

8.8

10.9

12.9

l/d	M3	M4	M5	M6	M8	M10	M12	M14	M16	M20
5	3x5	/	/	/	/	/	/	/	/	/
6	3x6	4x6	5x6	/	/	/	/	/	/	/
8	3x8	4x8	5x8	6x8	/	/	/	/	/	/
10	3x10	4x10	5x10	6x10	8x10	/	/	/	/	/
12	3x12	4x12	5x12	6x12	8x12	/	/	/	/	/
14*	3x14	4x14	5x14	6x14	8x14	/	/	/	/	/
16	3x16	4x16	5x16	6x16	8x16	10x16	/	/	/	/
18*	3x18	4x18	5x18	6x18	8x18	/	/	/	/	/
20	3x20	4x20	5x20	6x20	8x20	10x20	12x20	/	/	/
22*	/	4x22	5x22	6x22	8x22	/	/	/	/	/
25	3x25	4x25	5x25	6x25	8x25	10x25	12x25	14x25	16x25	/
30	3x30	4x30	5x30	6x30	8x30	10x30	12x30	14x30	16x30	/
35	3x35	4x35	5x35	6x35	8x35	10x35	12x35	14x35	16x35	/
40	3x40	4x40	5x40	6x40	8x40	10x40	12x40	14x40	16x40	20x40
45	/	4x45	5x45	6x45	8x45	10x45	12x45	14x45	16x45	20x45

l/d	M3	M4	M5	M6	M8	M10	M12	M14	M16	M20
50	/	4x50	5x50	6x50	8x50	10x50	12x50	14x50	16x50	20x50
55	/	/	5x55	6x55	8x55	10x55	12x55	/	16x55	/
60	/	4x60	5x60	6x60	8x60	10x60	12x60	14x60	16x60	20x60
65	/	/	5x65	6x65	8x65	10x65	12x65	/	16x65	/
70	/	4x70	5x70	6x70	8x70	10x70	12x70	14x70	16x70	20x70
75*	/	/	5x75	/	8x75	10x75	/	/	/	/
80	/	/	5x80	6x80	8x80	10x80	12x80	14x80	16x80	20x80
90	/	/	5x90	6x90	8x90	10x90	12x90	/	16x90	20x90
100	/	/	5x100	6x100	8x100	10x100	12x100	14x100	16x100	20x100
110	/	/	/	/	8x110	10x110	12x110	/	16x110	20x110
120	/	/	/	6x120	8x120	10x120	12x120	/	16x120	/
130	/	/	/	/	8x130	10x130	12x130	/	/	/
140	/	/	/	/	8x140	10x140	12x140	/	16x140	20x140
150	/	/	/	/	8x150	/	12x150	/	/	20x150

\* Longueurs non prévues par l'ISO 10642 et à considérer comme similaires

These measures aren't ISO 10642 but you can consider them similar DIN

Les longueurs standard sont celles comprises entre les deux lignes en gras.

The range of commercial lengths is between the bold stepped lines.

= Les mesures non surlignées (blanc), qui selon la norme ISO 10642, devraient avoir un filetage partiel, sont en fait un filetage total et donc à considérer comme similaire

The not highlighted measures (white) should have a partial thread, according to the ISO 10642 norm, while ours are actually total thread and are therefore to be considered as "similar to"

= Les mesures surlignées en bleu correspondent au filetage total conformément à la norme ISO 10642

The blue highlighted measures are total thread in accordance with ISO 10642